

PST KP604

HIGH POWER PHASE CONTROL THYRISTOR FOR PHASE CONTROL APPLICATIONS

Features :

- Blocking Capability up to 1600 V
- High dV/dt Capability
- All Diffused Structure
- Amplifying Gate Configuration
- Rugged Ceramic Hermetic Package

ELECTRICAL CHARACTERISTICS AND RATINGS

Blocking

Parameter	Symbol	Min	Max	Typ	Unit	Conditions
Repetitive peak reverse voltage	V_{RRM}		1600		V	$T_j = -40\text{ }^{\circ}\text{C}$ to $125\text{ }^{\circ}\text{C}$
Repetitive peak off-state voltage	V_{DRM}		1600		V	$T_j = -40\text{ }^{\circ}\text{C}$ to $125\text{ }^{\circ}\text{C}$
Non repetitive peak reverse voltage	V_{RSM}		1700		V	$T_j = -40\text{ }^{\circ}\text{C}$ to $125\text{ }^{\circ}\text{C}$
Repetitive peak reverse current	I_{RRM}		50		mA	$T_j = T_{jmax}$, $V = V_{RRM}$
Repetitive peak off-state current	I_{DRM}		50		mA	$T_j = T_{jmax}$, $V = V_{DRM}$

Conducting

Parameter	Symbol	Min	Max	Typ	Unit	Conditions
Average value of on-state current	$I_{T(AV)}$		530		A	50 Hz sine wave, 180° conduction, $T_c = 85\text{ }^{\circ}\text{C}$
RMS value of on-state current	$I_{T(RMS)}$		832		A	50 Hz sine wave, 180° conduction, $T_c = 85\text{ }^{\circ}\text{C}$
Surge non repetitive current	I_{TSM}		8.5		kA	50 Hz sine wave Half cycle
I square t	$I^2 t$		361		kA^2s	$V_R = 0$ $T_j = T_{jmax}$
Peak on-state voltage	V_{TM}		1.9		V	On-state current 1000 A, $T_j = T_{jmax}$
Threshold voltage	$V_{T(TO)}$		1.06		V	$T_j = T_{jmax}$
On-state slope resistance	r_T		0.84		$\text{m}\Omega$	$T_j = T_{jmax}$
Holding current	I_H			300	mA	$V_D = 12\text{ V}$; $I_T = 2.5\text{ A}$
Latching current	I_L			700	mA	$V_D = 12\text{ V}$; $R_L = 12\text{ }\Omega$

PST KP604

HIGH POWER PHASE CONTROL THYRISTOR

Triggering

Parameter	Symbol	Min	Max	Typ	Unit	Conditions
Gate current	I_{GT}		300		mA	$V_D = 6\text{ V}, R_L = 3\ \Omega, T_j = -40\ ^\circ\text{C}$
			200		mA	$V_D = 6\text{ V}, R_L = 3\ \Omega, T_j = 25\ ^\circ\text{C}$
			125		mA	$V_D = 6\text{ V}, R_L = 3\ \Omega, T_j = 125\ ^\circ\text{C}$
Gate voltage	V_{GT}		5		V	$V_D = 6\text{ V}, R_L = 3\ \Omega, T_j = -40\ ^\circ\text{C}$
			3.5		V	$V_D = 6\text{ V}, R_L = 3\ \Omega, T_j = 0 \div 125\ ^\circ\text{C}$
		0.25			V	$V_D = V_{DRM}, R_L = 1\ \text{k}\Omega, T_j = 125\ ^\circ\text{C}$
Peak gate current	I_{GM}		10		A	
Peak reverse gate voltage	V_{RGM}		5		V	
Peak gate power dissipation	P_{GM}		150		W	
Average gate power dissipation	$P_{G(AV)}$		2		W	

Switching

Parameter	Symbol	Min	Max	Typ	Unit	Conditions
Critical rate of rise of on-state current	di/dt		200		A/ μs	$I_G = 5 \cdot I_{GT}, t_r = 1\ \mu\text{s}, V_{DRM} \leq 1000\text{V}, T_j = T_{jmax}$
Critical rate of rise of on-state voltage	dv/dt		500		V/ μs	Linear ramp up to 80% of V_{DRM}
Gate controlled delay time	t_d			1.5	μs	$I_{TM} = 50\text{ A}, V_D = 67\% V_{DRM}, V_G = 20\text{ V}$ $R_G = 20\ \Omega, t_r = 0.1\ \mu\text{s}, t_p = 20\ \mu\text{s}$
Turn-off time	t_q			220	μs	$I_{TM} = 500\text{ A}; di/dt = 20\text{ A}/\mu\text{s}; V_R \geq 50\text{ V}$ $dV/dt = 20\text{ V}/\mu\text{s}$ linear to 67% V_{DRM} $V_G = 0\text{ V}; T_j = T_{jmax}$
Reverse recovery charge	Q_{rr}				μC	$I_T = 500\text{ A}$ $di/dt = 20\text{ A}/\mu\text{s}$
Reverse recovery current	I_{rr}				A/ μs	$V_R \geq 50\text{ V}$ $T_j = T_{jmax}$

Thermal and mechanical

Parameter	Symbol	Min	Max	Typ	Unit	Conditions
Operating temperature	T_j	-40	125		$^\circ\text{C}$	
Storage temperature	T_{stg}	-40	150		$^\circ\text{C}$	
Thermal resistance junction to case	$R_{th(j-c)}$		0.035		$^\circ\text{C}/\text{W}$	Double side cooled, 180° SIN
Thermal resistance case to sink	$R_{th(c-s)}$		0.015		$^\circ\text{C}/\text{W}$	Double side cooled, mounting surfaces smooth, flat and greased
Mounting force	F	8	9		kN	
Weight	W			85	g	

PST KP604

HIGH POWER PHASE CONTROL THYRISTOR

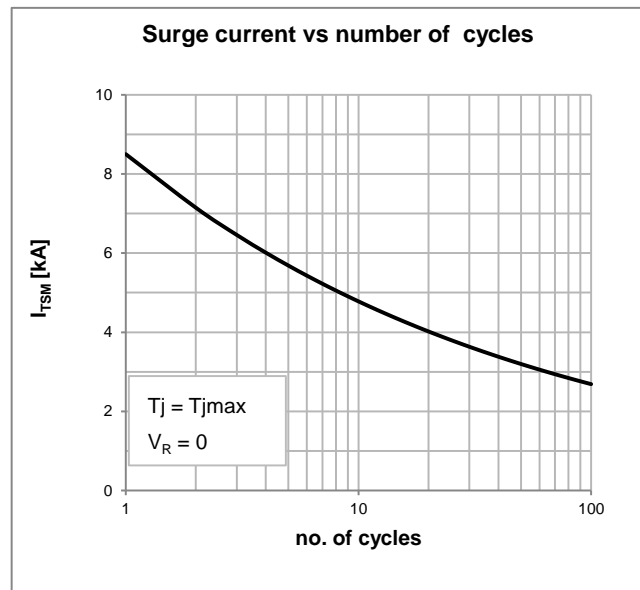
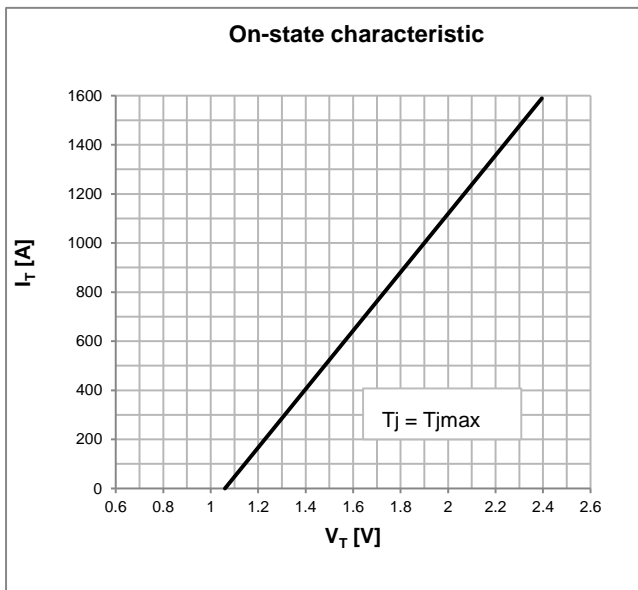
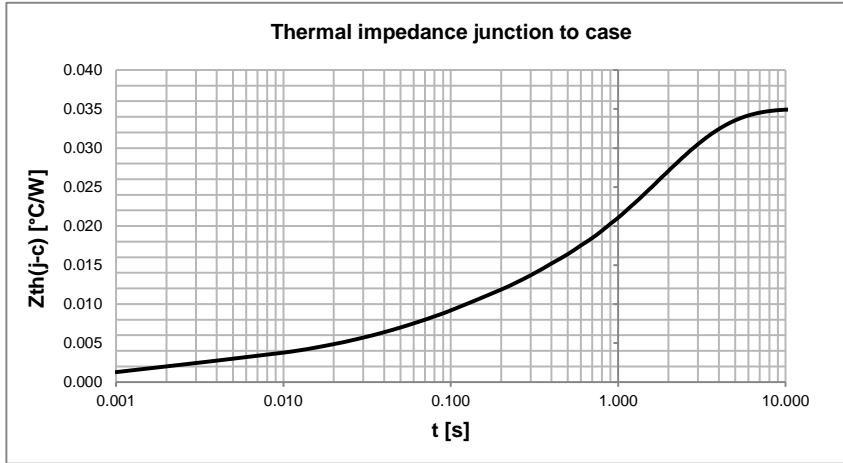

OUTLINE AND DIMENSIONS

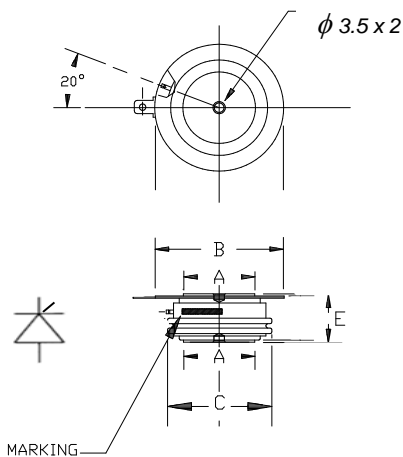

	A	B	C	E
mm	25	42	40	14 ± 0.5

- All the characteristics given in this data sheet are guaranteed only with uniform clamping force, cleaned and lubricated heatsink surfaces with flatness < 0.03 mm and roughness < 2µm