



# PST KP4301

## HIGH POWER PHASE CONTROL THYRISTOR FOR PHASE CONTROL APPLICATIONS

### Features :

- Blocking Capability up to 2200 V
- High dV/dt Capability
- All Diffused Structure
- Amplifying Gate Configuration
- Rugged Ceramic Hermetic Package

### ELECTRICAL CHARACTERISTICS AND RATINGS

#### Blocking

Parameter	Symbol	Min	Max	Typ	Unit	Conditions
Repetitive peak reverse voltage	$V_{RRM}$		2200		V	$T_j = -40\text{ }^{\circ}\text{C}$ to $125\text{ }^{\circ}\text{C}$
Repetitive peak off-state voltage	$V_{DRM}$		2200		V	$T_j = -40\text{ }^{\circ}\text{C}$ to $125\text{ }^{\circ}\text{C}$
Non repetitive peak reverse voltage	$V_{RSM}$		2300		V	$T_j = -40\text{ }^{\circ}\text{C}$ to $125\text{ }^{\circ}\text{C}$
Repetitive peak reverse current	$I_{RRM}$		300		mA	$T_j = T_{jmax}$ , $V = V_{RRM}$
Repetitive peak off-state current	$I_{DRM}$		300		mA	$T_j = T_{jmax}$ , $V = V_{DRM}$

#### Conducting

Parameter	Symbol	Min	Max	Typ	Unit	Conditions
Average value of on-state current	$I_{T(AV)}$		4030		A	50 Hz sine wave, $180^{\circ}$ conduction, $T_c = 85\text{ }^{\circ}\text{C}$
RMS value of on-state current	$I_{T(RMS)}$		6330		A	50 Hz sine wave, $180^{\circ}$ conduction, $T_c = 85\text{ }^{\circ}\text{C}$
Surge non repetitive current	$I_{TSM}$		91		kA	50 Hz sine wave Half cycle
I square t	$I^2 t$		41405		$\text{kA}^2\text{s}$	$V_R = 0$ $T_j = T_{jmax}$
Peak on-state voltage	$V_{TM}$		1.2		V	On-state current 4000 A, $T_j = T_{jmax}$
Threshold voltage	$V_{T(TO)}$		0.77		V	$T_j = T_{jmax}$
On-state slope resistance	$r_T$		0.11		m $\Omega$	$T_j = T_{jmax}$
Holding current	$I_H$			350	mA	$V_D = 12\text{ V}$ ; $I_T = 2.5\text{ A}$
Latching current	$I_L$			1000	mA	$V_D = 12\text{ V}$ ; $R_L = 12\text{ }\Omega$

# PST KP4301

## HIGH POWER PHASE CONTROL THYRISTOR

### Triggering

Parameter	Symbol	Min	Max	Typ	Unit	Conditions
Gate current	$I_{GT}$		300		mA	$V_D = 6\text{ V}; R_L = 3\ \Omega; T_j = -40\ ^\circ\text{C}$
			200		mA	$V_D = 6\text{ V}; R_L = 3\ \Omega; T_j = 25\ ^\circ\text{C}$
			125		mA	$V_D = 6\text{ V}; R_L = 3\ \Omega; T_j = 125\ ^\circ\text{C}$
Gate voltage	$V_{GT}$		5		V	$V_D = 6\text{ V}; R_L = 3\ \Omega; T_j = -40\ ^\circ\text{C}$
			4		V	$V_D = 6\text{ V}; R_L = 3\ \Omega; T_j = 0 \div 125\ ^\circ\text{C}$
		0.3			V	$V_D = V_{DRM}; R_L = 10\ \text{k}\Omega; T_j = 125\ ^\circ\text{C}$
Peak gate current	$I_{GM}$		15		A	
Peak reverse gate voltage	$V_{RGM}$		15		V	
Peak gate power dissipation	$P_{GM}$		200		W	
Average gate power dissipation	$P_{G(AV)}$		5		W	

### Switching

Parameter	Symbol	Min	Max	Typ	Unit	Conditions
Critical rate of rise of on-state current	$di/dt$		300		A/ $\mu\text{s}$	$I_G = 5 \cdot I_{GT}; t_r = 1\ \mu\text{s}; T_j = T_{jmax}$
Critical rate of rise of on-state voltage	$dv/dt$		1000		V/ $\mu\text{s}$	Linear ramp up to 80% of $V_{DRM}$
Gate controlled delay time	$t_d$				$\mu\text{s}$	$I_{TM} = 50\text{ A}; V_D = 1500\text{ V}; V_G = 20\text{ V}$ $R_G = 20\ \Omega; t_r = 0.1\ \mu\text{s}; t_p = 20\ \mu\text{s}$
Turn-off time	$t_q$			250	$\mu\text{s}$	$I_{TM} = 4300\text{ A}; di/dt = 10\text{ A}/\mu\text{s}; V_R \geq 100\text{ V}$ $dv/dt = 20\text{ V}/\mu\text{s}$ linear to 67% $V_{DRM}$ $V_G = 0\text{ V}; T_j = T_{jmax}$
Reverse recovery charge	$Q_{rr}$				$\mu\text{C}$	$I_T = 500\text{ A}$ $di/dt = 20\text{ A}/\mu\text{s}$
Reverse recovery current	$I_{rr}$				A/ $\mu\text{s}$	$V_R \geq 50\text{ V}$ $T_j = T_{jmax}$

### Thermal and mechanical

Parameter	Symbol	Min	Max	Typ	Unit	Conditions
Operating temperature	$T_j$	-40	125		$^\circ\text{C}$	
Storage temperature	$T_{stg}$	-40	150		$^\circ\text{C}$	
Thermal resistance junction to case	$R_{th(j-c)}$		0.0055		$^\circ\text{C}/\text{W}$	Double side cooled, $180^\circ\text{SIN}$
Thermal resistance case to sink	$R_{th(c-s)}$		0.0015		$^\circ\text{C}/\text{W}$	Double side cooled, mounting surfaces smooth, flat and greased
Mounting force	$F$	60	90		kN	
Weight	$W$			2800	g	

# PST KP4301

## HIGH POWER PHASE CONTROL THYRISTOR

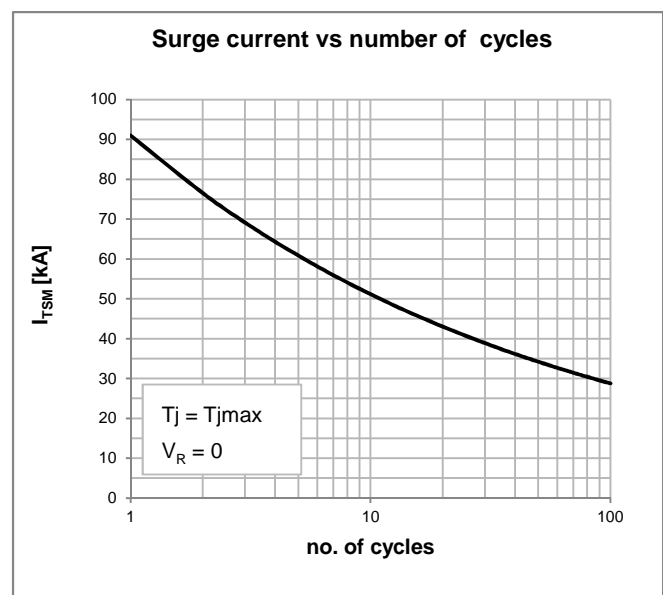
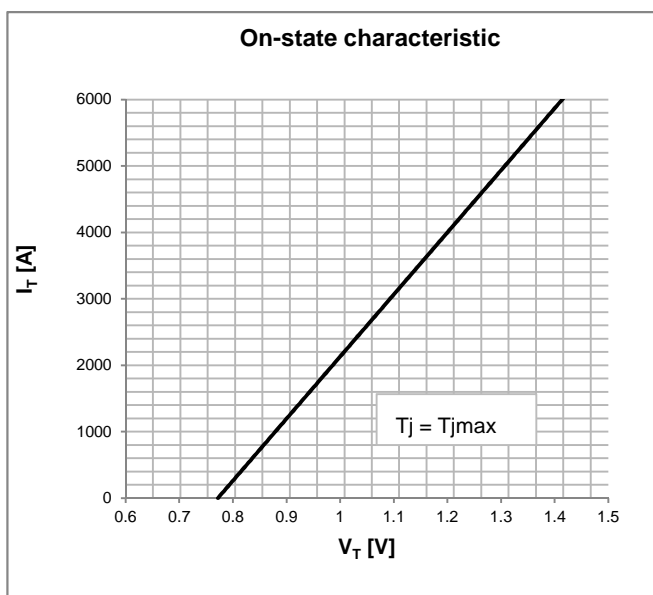
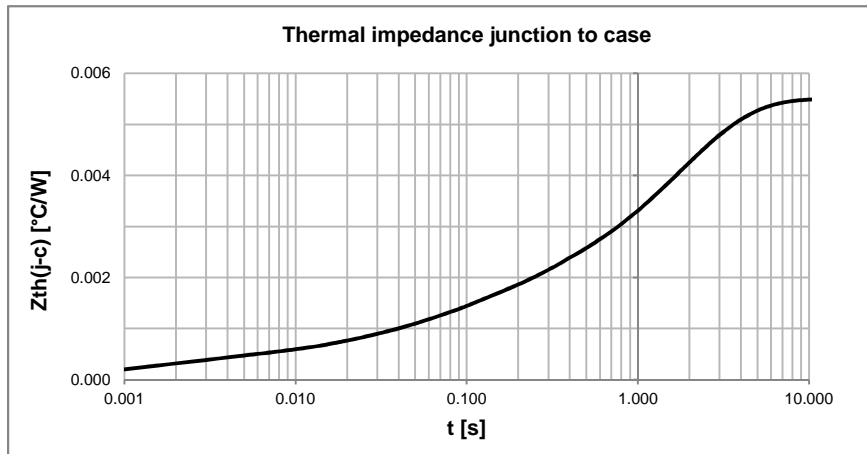

### OUTLINE AND DIMENSIONS

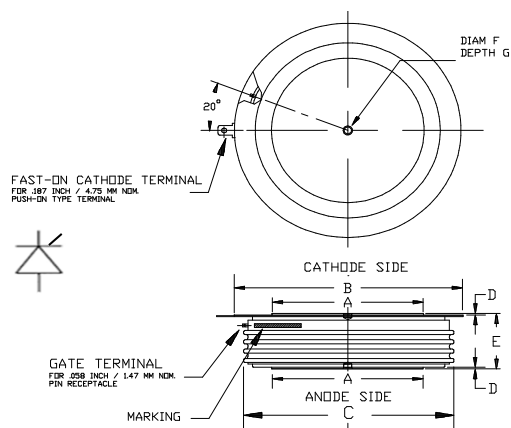

	A	B	C	E
mm	100	150	131	35+/-1
inches	3.93	5.90	5.15	1.37

- All the characteristics given in this data sheet are guaranteed only with uniform clamping force, cleaned and lubricated heatsink surfaces with flatness < 0.03 mm and roughness < 2µm