

## PST ZP372X

### RECTIFIER DIODE

#### Features

- Blocking Capability up to 4500 V
- High Surge Rating
- Rugged Ceramic Hermetic Package

#### ELECTRICAL CHARACTERISTICS AND RATINGS

##### Blocking

Parameter	Symbol	Min	Max	Typ	Unit	Conditions
Repetitive peak reverse voltage	$V_{RRM}$		4500		V	$T_j = -40\text{ °C to }150\text{ °C}$
Non repetitive peak reverse voltage	$V_{RSM}$		4600		V	$T_j = -40\text{ °C to }150\text{ °C}$
Repetitive peak reverse current	$I_{RRM}$		18		mA	$T_j = T_{jmax}$ , $V = V_{RRM}$

##### Conducting

Parameter	Symbol	Min	Max	Typ	Unit	Conditions
Average value of forward current	$I_{F(AV)}$		535		A	50 Hz sinewave, 180° conduction, $T_c = 85\text{ °C}$
RMS value of forward current	$I_{F(RMS)}$		840		A	50 Hz sinewave, 180° conduction, $T_c = 85\text{ °C}$
Peak one cycle surge (non repetitive) current	$I_{FSM}$		5		kA	50 Hz sinewave, 180° conduction, $T_j = T_{jmax}$ , $V_R = 0$
I square t	$I^2 t$		125		$kA^2s$	$T_j = T_{jmax}$
Peak forward voltage	$V_{FM}$		1.18		V	Forward current 150 A, $T_j = T_{jmax}$
Threshold voltage	$V_{F(TO)}$		0.96		V	$T_j = T_{jmax}$
Forward slope resistance	$r_F$		1.48		mΩ	$T_j = T_{jmax}$
Reverse recovery charge	$Q_{rr}$	500	650		μC	$I_F = 100\text{ A}$ , $di_F / dt = 10\text{ A}/\mu s$ , $V_R = 50\text{ V}$ , $T_j = T_{jmax}$

##### Thermal and mechanical characteristics and ratings

Parameter	Symbol	Min	Max	Typ	Unit	Conditions
Operating temperature	$T_j$	-40	150		°C	
Storage temperature	$T_{stg}$	-40	150		°C	
Thermal resistance junction to case	$R_{th(j-c)}$		0.041		°C/W	Double side cooled, 180° SIN
Thermal resistance case to sink	$R_{th(c-s)}$		0.007		°C/W	Mounting surfaces smooth, flat and greased
Mounting force	<b>F</b>	8	10		kN	
Weight	<b>W</b>			300	g	

# PST ZP372X

## RECTIFIER DIODE

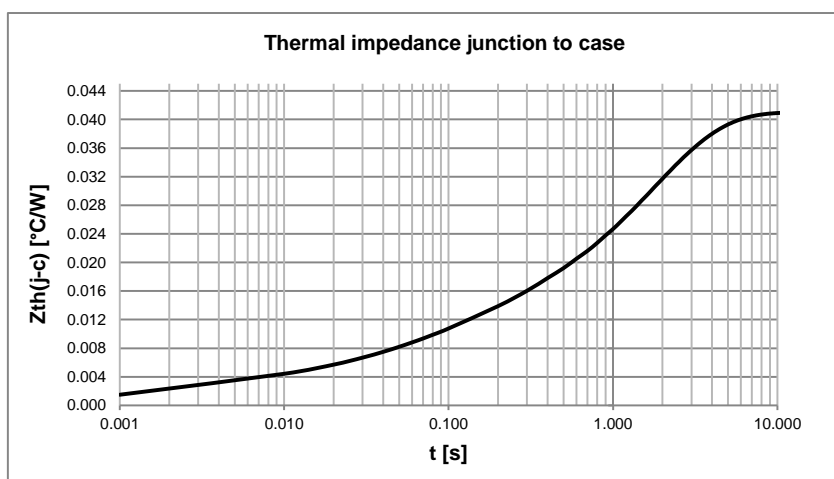
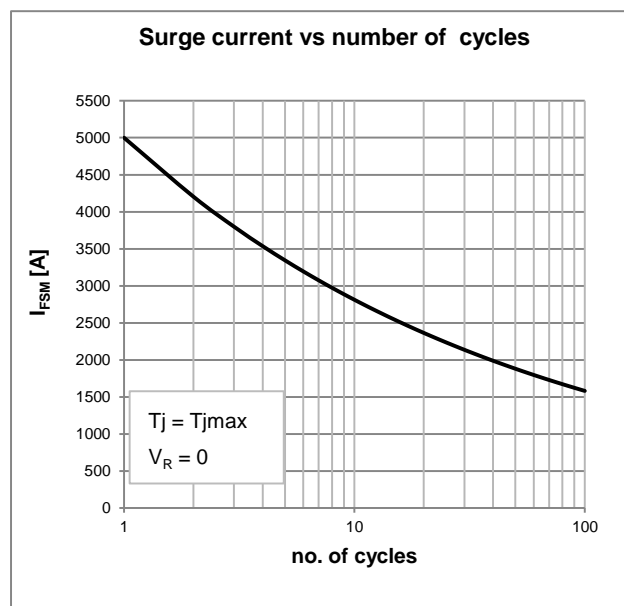
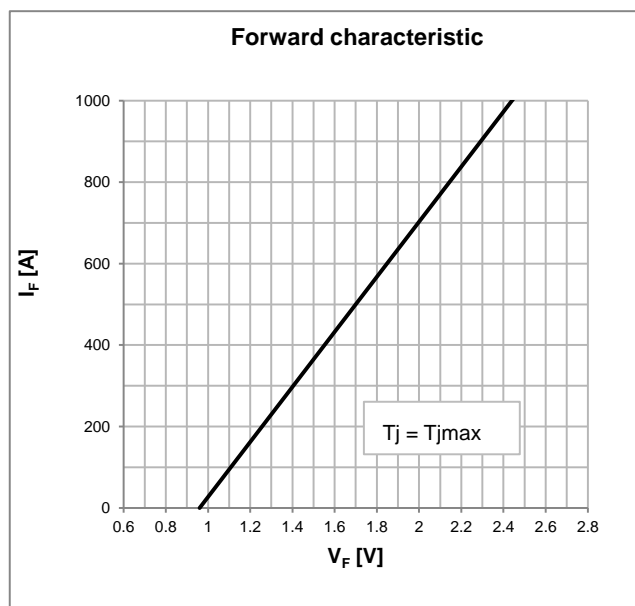

## OUTLINE AND DIMENSIONS

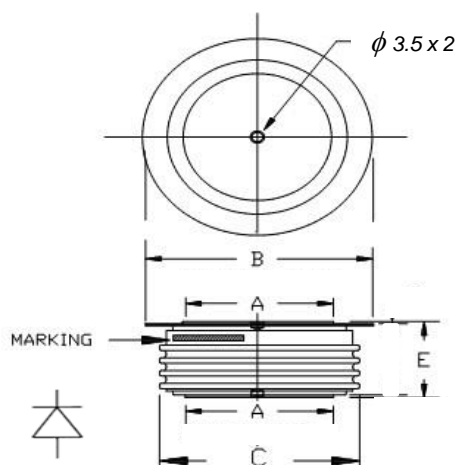

	A	B	C	E
mm	34	64	55	$26 \pm 0.5$

- All the characteristics given in this data sheet are guaranteed only with uniform clamping force, cleaned and lubricated heatsink surfaces with flatness  $< 0.03$  mm and roughness  $< 2\mu\text{m}$