

## PST MTC320

### THYRISTOR MODULE

#### Features:

- Heat transfer through aluminium nitride ceramic isolated metal base
- Precious metal pressure contacts for high reliability
- Thyristor with amplifying gate

#### Typical applications:

- DC motor control
- Temperature control
- Professional light dimming

### ELECTRICAL CHARACTERISTICS AND RATINGS

#### Reverse blocking - Off-state

Device Type	$V_{RRM}$ (1)	$V_{DRM}$ (1)	$V_{RSM}$ (1)
PST MTC320	1600 V	1600 V	1700 V

$V_{RRM}$  = Repetitive peak reverse voltage

$V_{DRM}$  = Repetitive peak off-state voltage

$V_{RSM}$  = Non repetitive peak reverse voltage (2)

Repetitive reverse and off-state peak leakage current	$I_{RRM}, I_{DRM}$	50 mA (3)
Critical rate of rise of off-state voltage	$dv/dt$	1000 V/ $\mu$ s (4)

Notes:

All ratings are specified for  $T_j = 25^\circ\text{C}$  unless otherwise stated.

(1) All voltage ratings are specified for an applied 50Hz/60Hz sinusoidal waveform over the temperature range  $-40$  to  $+130^\circ\text{C}$ .

(2) 10 ms max. pulse width

(3) Maximum value for  $T_j = T_{jmax}$

(4) Min. value for linear and exponential wave shape to 80% rated  $V_{DRM}$ .

Gate open.  $T_j = T_{jmax}$

#### Conducting

Parameter	Symbol	Min	Max	Typ	Unit	Conditions
Average value of on-state current	$I_{T(AV)}$		320		A	50 Hz sine wave, $180^\circ$ conduction, $T_c = 85^\circ\text{C}$
RMS value of on-state current	$I_{T(RMS)}$		500		A	50 Hz sine wave, $180^\circ$ conduction, $T_c = 85^\circ\text{C}$
Surge non repetitive current	$I_{TSM}$		8.2		kA	50 Hz sine wave Half cycle
I squared t	$I^2 t$		336		$\text{kA}^2\text{s}$	$V_R = 0$ $T_j = T_{jmax}$
Peak on-state voltage	$V_{TM}$		1.10		V	On-state current 600 A, $T_j = T_{jmax}$
Threshold voltage	$V_{T(TO)}$		0.8		V	$T_j = T_{jmax}$
On-state slope resistance	$r_T$		0.5		m $\Omega$	$T_j = T_{jmax}$
Holding current	$I_H$			150	mA	$T_j = 25^\circ\text{C}$
Latching current	$I_L$			200	mA	$T_j = 25^\circ\text{C}$
Critical rate of rise of on-state current	$di/dt$		250		A/ $\mu$ s	$I_G = 5 I_{GT}$ , $t_r = 1 \mu\text{s}$ , $T_j = T_{jmax}$ , non rep.
RMS isolation voltage	$V_{INS}$		3000		V	AC 50 Hz, 60 s

# PST MTC320

## THYRISTOR MODULE

### Triggering

Parameter	Symbol	Min	Max	Typ	Unit	Conditions
Gate current	$I_{GT}$		150		mA	$V_D = 6\text{ V}; R_L = 3\ \Omega; T_j = 25\text{ }^\circ\text{C}$
Gate voltage	$V_{GT}$		2		V	$V_D = 6\text{ V}; R_L = 3\ \Omega; T_j = 25\text{ }^\circ\text{C}$

### Thermal and mechanical characteristics and ratings

Parameter	Symbol	Min	Max	Typ	Unit	Conditions
Operating temperature	$T_j$	-40	130		$^\circ\text{C}$	
Storage temperature	$T_{stg}$	-40	140		$^\circ\text{C}$	
Thermal resistance junction to case (per module)	$R_{th(j-c)}$		0.06		$^\circ\text{C/W}$	SIN 180° conduction mounting surfaces smooth, flat and greased
Thermal resistance case to sink (per module)	$R_{th(c-s)}$		0.02		$^\circ\text{C/W}$	
Mounting torque case-heatsink	$T$	5	7		N·m	
Mounting torque busbar-terminals	$T$	10	13		N·m	
Weight	$W$			700	g	

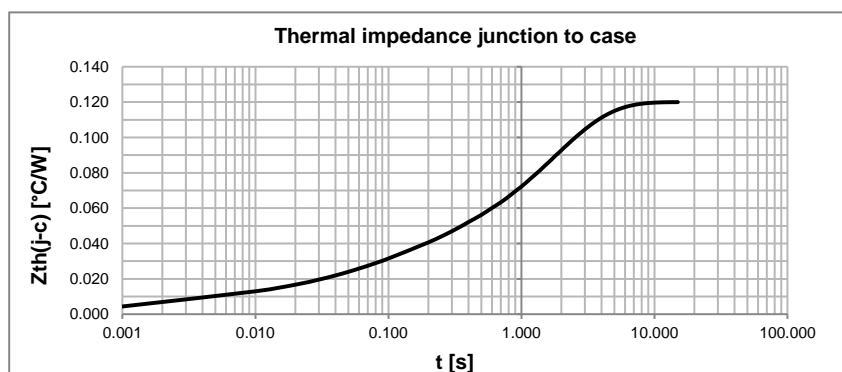
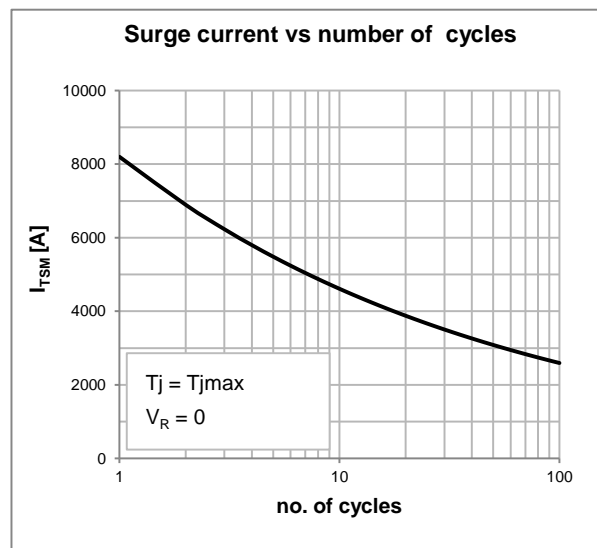
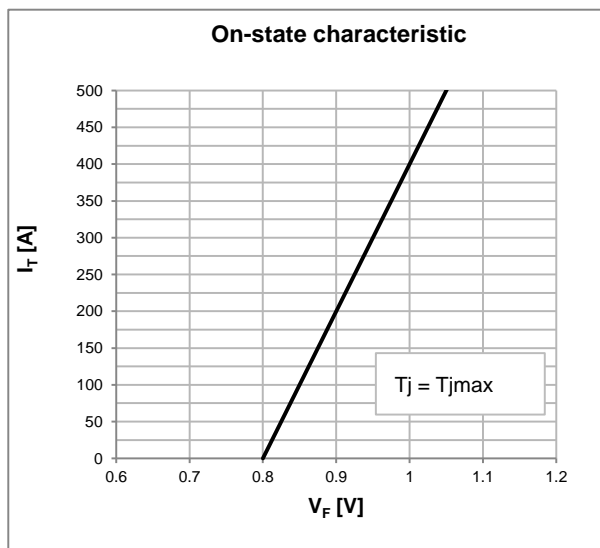

# PST MTC320

## THYRISTOR MODULE

### OUTLINE AND DIMENSIONS

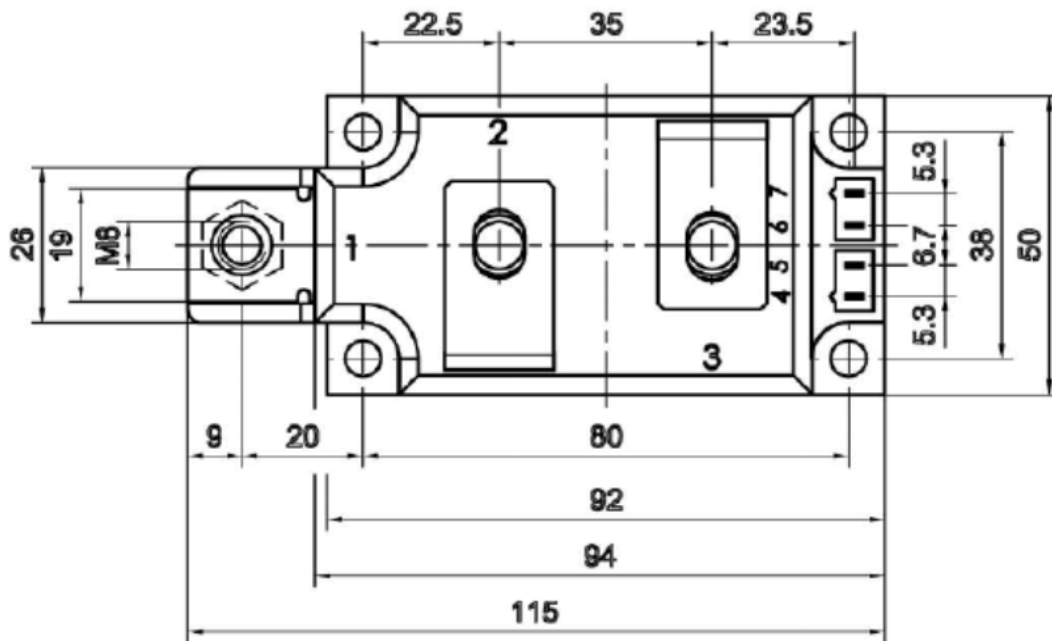
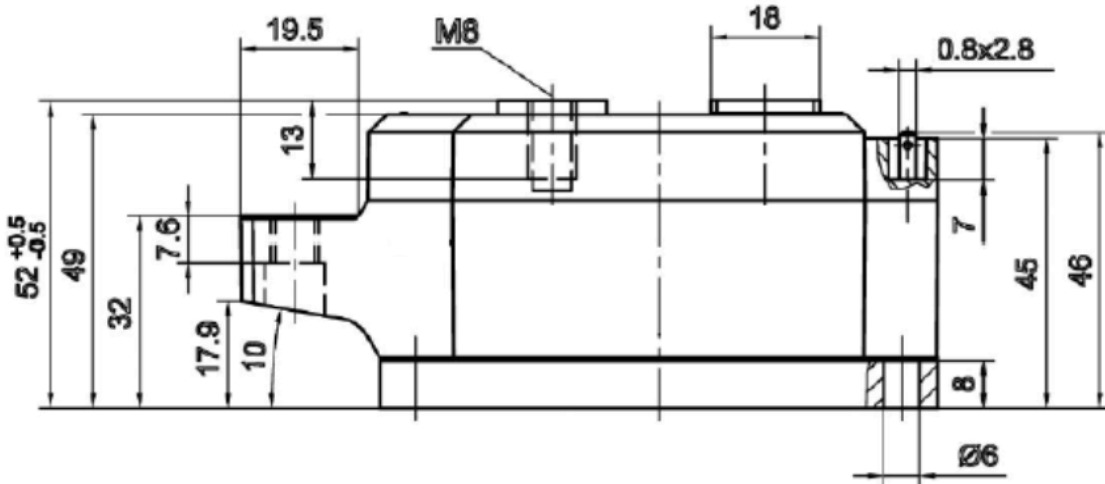

dimensions in mm

