

PST MTC25

THYRISTOR MODULE

Features:

- Electrically isolated base plate
- High surge capability
- Hard soldered joints for high reliability

Typical applications:

- AC motor soft starters
- DC motor control (e.g. for machine tools)
- Temperature control (e.g. for ovens, chemical processes)

ELECTRICAL CHARACTERISTICS AND RATINGS

Reverse blocking - Off-state

Device Type	V_{RRM} (1)	V_{DRM} (1)	V_{RSM} (1)
PST MTC25	1600 V	1600 V	1700 V

V_{RRM} = Repetitive peak reverse voltage

V_{DRM} = Repetitive peak off-state voltage

V_{RSM} = Non repetitive peak reverse voltage (2)

Repetitive reverse and off-state peak leakage current	I_{RRM}, I_{DRM}	10 mA (3)
Critical rate of rise of off-state voltage	dv/dt	1000 V/ μ s (4)

Notes:

All ratings are specified for $T_j = 25^\circ\text{C}$ unless otherwise stated.

(1) All voltage ratings are specified for an applied 50Hz/60Hz sinusoidal waveform over the temperature range to $+125^\circ\text{C}$.

(2) 10 ms max. pulse width

(3) Maximum value for $T_j = T_{jmax}$

(4) Min. value for linear and exponential wave shape to 80% rated V_{DRM} .

Gate open. $T_j = T_{jmax}$

Conducting

Parameter	Symbol	Min	Max	Typ	Unit	Conditions
Average value of on-state current	$I_{T(AV)}$		25		A	50 Hz sine wave, 180° conduction, $T_c = 85^\circ\text{C}$
RMS value of on-state current	$I_{T(RMS)}$		40		A	50 Hz sine wave, 180° conduction, $T_c = 85^\circ\text{C}$
Surge non repetitive current	I_{TSM}		0.48		kA	50 Hz sine wave Half cycle
I squared t	$I^2 t$		1.2		kA^2s	$V_R = 0$ $T_j = T_{jmax}$
Peak on-state voltage	V_{TM}		1.80		V	On-state current 75 A, $T_j = T_{jmax}$
Threshold voltage	$V_{T(TO)}$		0.9		V	$T_j = T_{jmax}$
On-state slope resistance	r_T		12.0		m Ω	$T_j = T_{jmax}$
Holding current	I_H			200	mA	$T_j = 25^\circ\text{C}$
Latching current	I_L			400	mA	$T_j = 25^\circ\text{C}$
Critical rate of rise of on-state current	di/dt		150		A/ μ s	$I_G = 5 I_{GT}$, $t_r = 1 \mu\text{s}$, $T_j = T_{jmax}$
RMS isolation voltage	V_{INS}		3000		V	AC 50 Hz, 60 s

PST MTC25

THYRISTOR MODULE

Triggering

Parameter	Symbol	Min	Max	Typ	Unit	Conditions
Gate current	I_{GT}		150		mA	$V_D = 6\text{ V}; R_L = 3\ \Omega; T_j = 25\text{ }^\circ\text{C}$
Gate voltage	V_{GT}		3		V	$V_D = 6\text{ V}; R_L = 3\ \Omega; T_j = 25\text{ }^\circ\text{C}$

Thermal and mechanical characteristics and ratings

Parameter	Symbol	Min	Max	Typ	Unit	Conditions
Operating temperature	T_j	-40	125		$^\circ\text{C}$	
Storage temperature	T_{stg}	-40	125		$^\circ\text{C}$	
Thermal resistance junction to case (per module)	$R_{th(j-c)}$		0.450		$^\circ\text{C/W}$	SIN 180° conduction mounting surfaces smooth, flat and greased
Thermal resistance case to sink (per module)	$R_{th(c-s)}$		0.100		$^\circ\text{C/W}$	
Mounting torque case-heatsink	T	4	6		N·m	
Mounting torque busbar-terminals	T	2.5	3.5		N·m	
Weight	W			100	g	

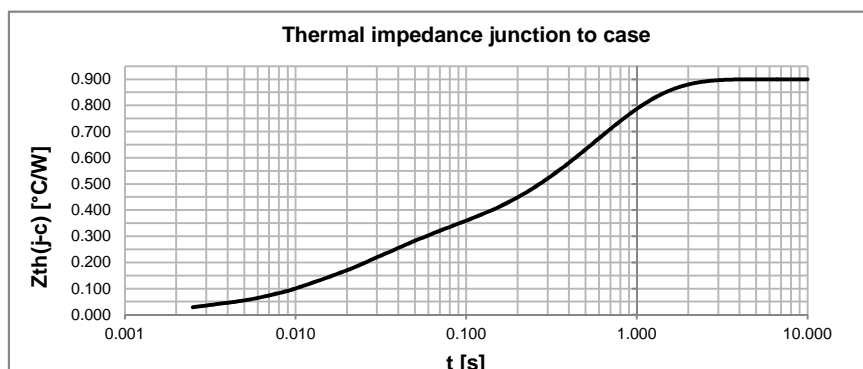
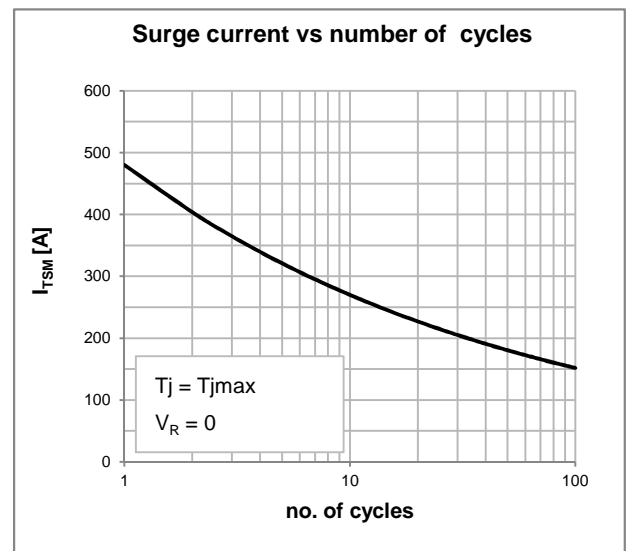
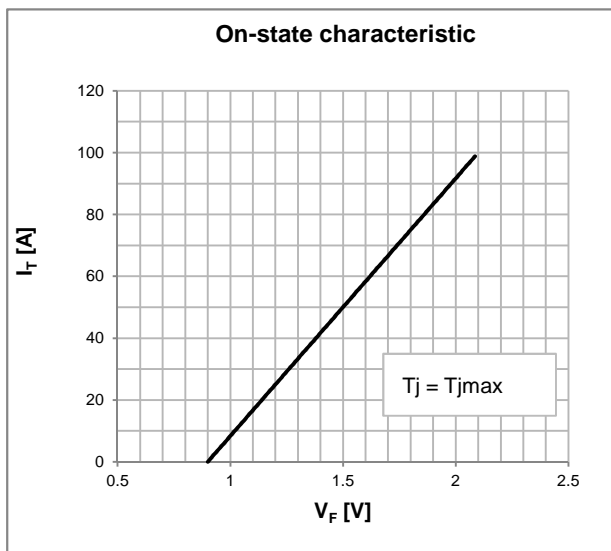

PST MTC25

THYRISTOR MODULE

OUTLINE AND DIMENSIONS

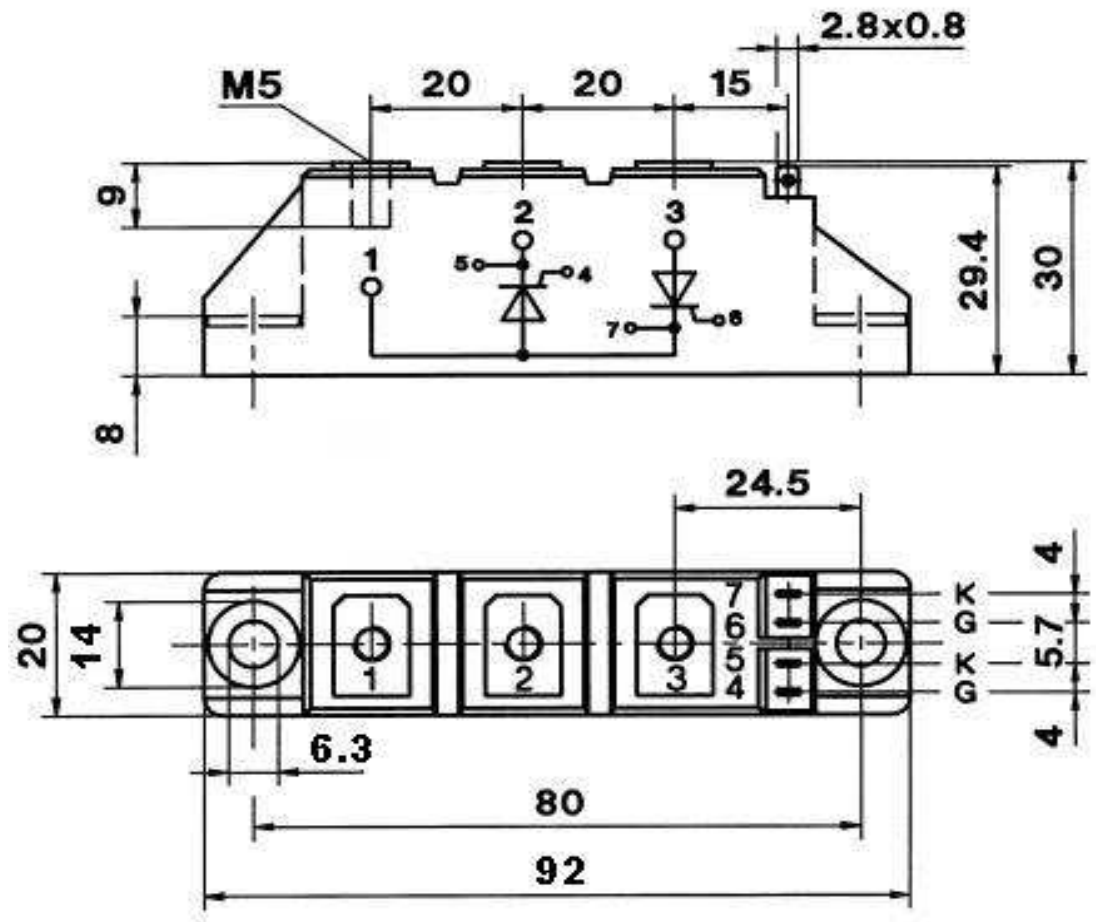

(all dimensions in mm)