



# Technical Data

## PST MCO500

### SINGLE THYRISTOR MODULE

#### Features:

- Electrically isolated base plate
- High surge capability
- Precious metal pressure contact

#### Typical applications:

- DC motor control (e.g. for machine tools)
- Temperature control (e.g. for ovens, chemical processes)
- Professional light dimming (e.g. for studios, theaters)

### ELECTRICAL CHARACTERISTICS AND RATINGS

#### Reverse blocking - Off-state

Device Type	$V_{RRM}$ (1)	$V_{DRM}$ (1)	$V_{RSM}$ (1)
PST MCO500	1600 V	1600 V	1700 V

$V_{RRM}$  = Repetitive peak reverse voltage

$V_{DRM}$  = Repetitive peak off-state voltage

$V_{RSM}$  = Non repetitive peak reverse voltage (2)

Repetitive reverse and off-state peak leakage current	$I_{RRM}, I_{DRM}$	70 mA (3)
Critical rate of rise of off-state voltage	$dv/dt$	1000 V/ $\mu$ s (4)

Notes:

All ratings are specified for  $T_j = 25^\circ\text{C}$  unless otherwise stated.

(1) All voltage ratings are specified for an applied 50Hz/60Hz sinusoidal waveform over the temperature range  $-40$  to  $+140^\circ\text{C}$ .

(2) 10 ms max. pulse width

(3) Maximum value for  $T_j = T_{jmax}$

(4) Min. value for linear and exponential wave shape to 67% rated  $V_{DRM}$ .

Gate open.  $T_j = T_{jmax}$

#### Conducting

Parameter	Symbol	Min	Max	Typ	Unit	Conditions
Average value of on-state current	$I_{T(AV)}$		560		A	50 Hz sine wave, $180^\circ$ conduction, $T_c = 85^\circ\text{C}$
RMS value of on-state current	$I_{T(RMS)}$		880		A	50 Hz sine wave, $180^\circ$ conduction, $T_c = 85^\circ\text{C}$
Surge non repetitive current	$I_{TSM}$		13		kA	50 Hz sine wave Half cycle
I squared t	$I^2 t$		845		$\text{kA}^2\text{s}$	$V_R = 0$ $T_j = T_{jmax}$
Peak on-state voltage	$V_{TM}$		1.26		V	On-state current 1200 A, $T_j = T_{jmax}$
Threshold voltage	$V_{T(TO)}$		0.81		V	$T_j = T_{jmax}$
On-state slope resistance	$r_T$		0.378		m $\Omega$	$T_j = T_{jmax}$
Holding current	$I_H$			300	mA	$T_j = 25^\circ\text{C}$
Latching current	$I_L$			400	mA	$T_j = 25^\circ\text{C}$
Critical rate of rise of on-state current	$di/dt$		100		A/ $\mu$ s	$I_G = 5 I_{GT}$ , $t_r = 1 \mu\text{s}$ , $T_j = T_{jmax}$
RMS isolation voltage	$V_{INS}$		3000		V	AC 50 Hz, 60 s

# PST MCO500

## SINGLE THYRISTOR MODULE

### Triggering

Parameter	Symbol	Min	Max	Typ	Unit	Conditions
Gate current	$I_{GT}$		300		mA	$V_D = 6\text{ V}; R_L = 6\ \Omega; T_j = 25\text{ }^\circ\text{C}$
Gate voltage	$V_{GT}$		3		V	$V_D = 6\text{ V}; R_L = 6\ \Omega; T_j = 25\text{ }^\circ\text{C}$

### Thermal and mechanical characteristics and ratings

Parameter	Symbol	Min	Max	Typ	Unit	Conditions
Operating temperature	$T_j$	-40	140		$^\circ\text{C}$	
Storage temperature	$T_{stg}$	-40	125		$^\circ\text{C}$	
Thermal resistance junction to case	$R_{th(j-c)}$		0.072		$^\circ\text{C/W}$	SIN 180° conduction mounting surfaces smooth, flat and greased
Thermal resistance case to sink	$R_{th(c-s)}$		0.024		$^\circ\text{C/W}$	
Mounting torque case-heatsink	$T$	4	7		N·m	
Mounting torque busbar-terminals	$T$	11	13		N·m	
Weight	$W$			810	g	

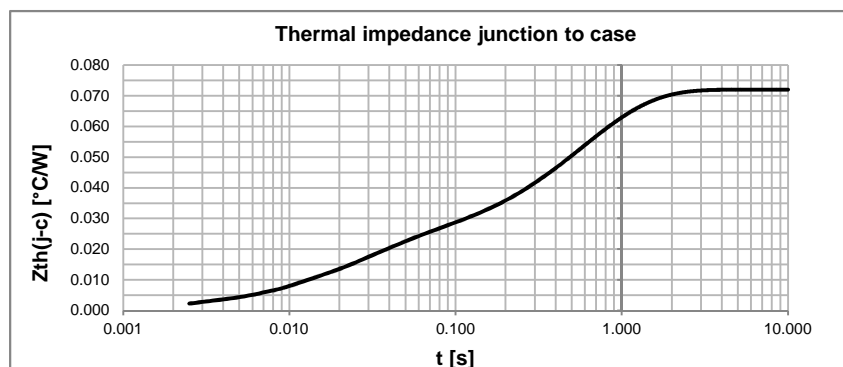
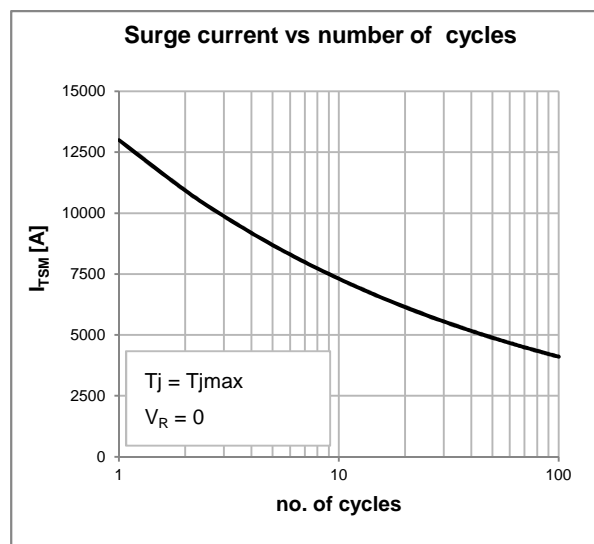
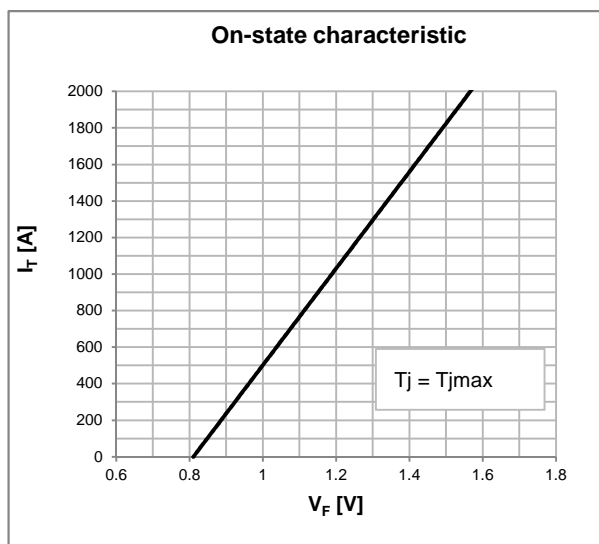

# PST MCO500

## SINGLE THYRISTOR MODULE

### OUTLINE AND DIMENSIONS

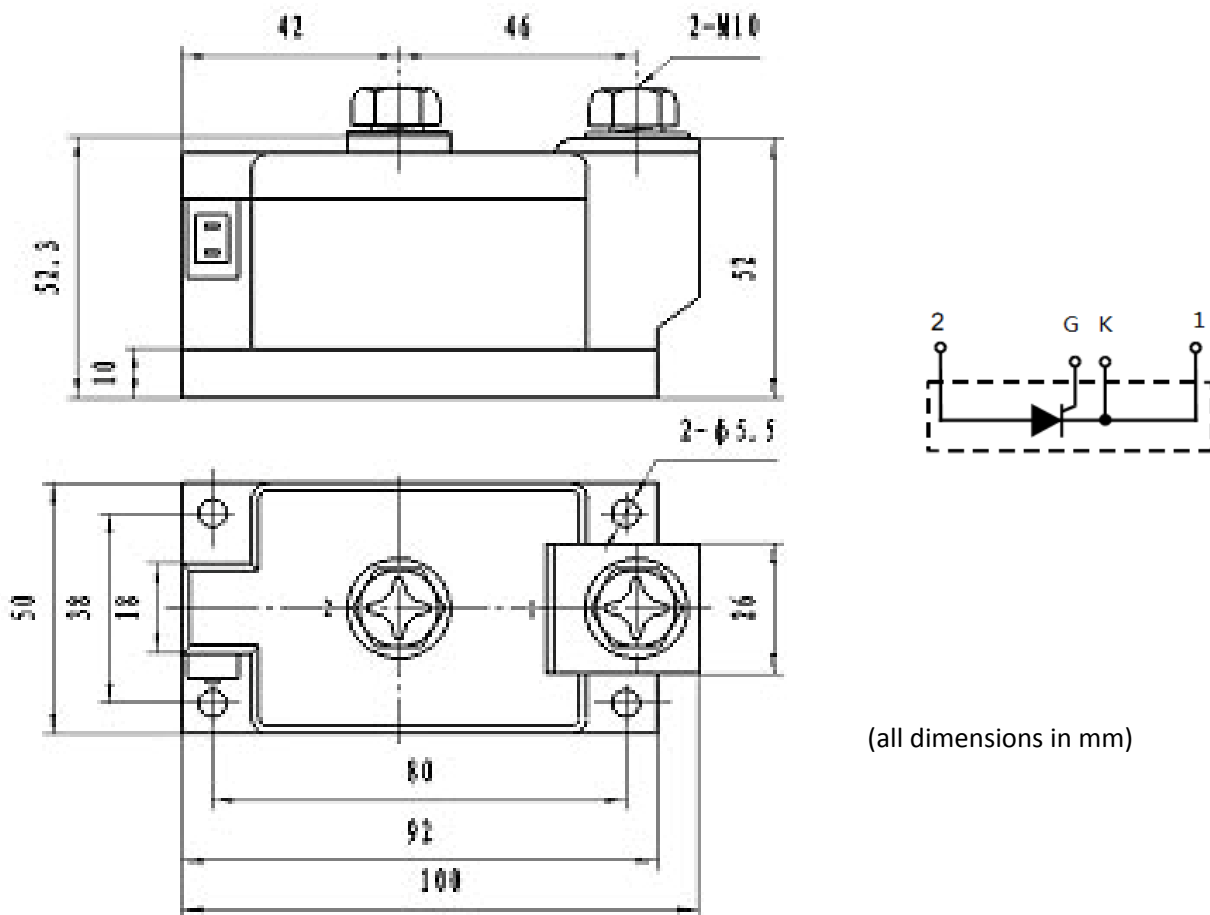

(all dimensions in mm)